

# The 28th JAPANTEX2009 INTERIOR TREND SHOW

November **11** (Wed.) - **13** (Fri.), 2009

10:00-18:00 \*Closed at 17:00 on the last day

**Tokyo Big Sight / West Hall**

Organized by Nippon Interior Fabrics Association



## About The JAPANTEX

THE JAPANTEX, which is renowned for exhibiting a great range of interior fabrics and interior accessories including software, machinery and maintenance products, is one of the largest international exhibition in the interior industry in Asia. It is a place where designers, manufacturers, wholesalers, distributors and retailers meet and exchange the latest trend and trade information.

If you want to expand your business in Japan and Asia-Pacific region, Come and participate in the show!

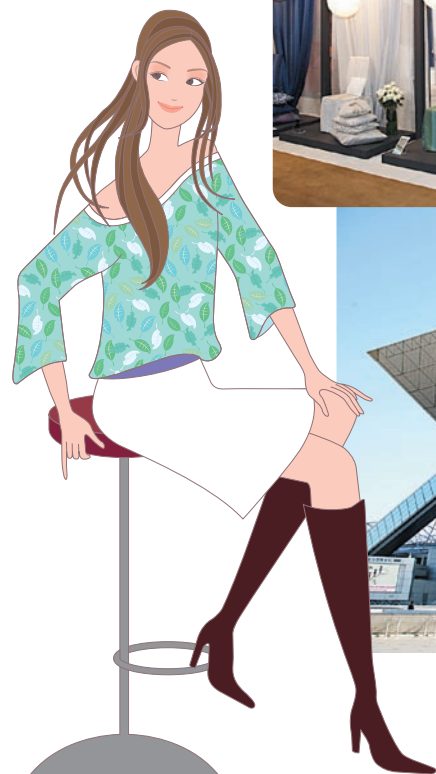
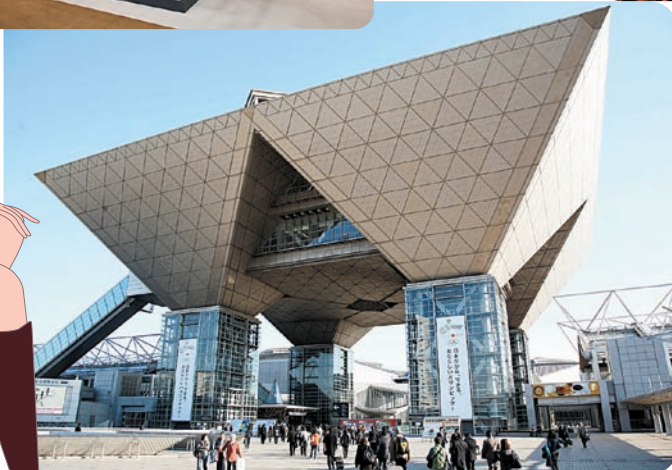
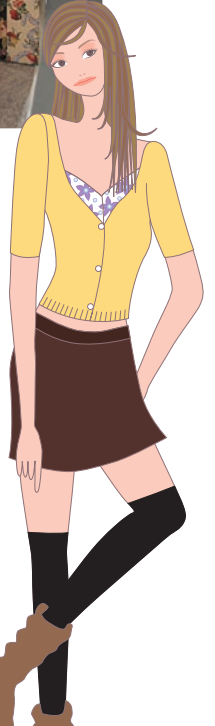

## Outline

**Title:** The 28th JAPANTEX2009 Interior Trend Show

**Organized by:** Nippon Interior Fabrics Association (NIF)

**Theme:** Good day, Good style

**Date:** November 11 (Wed.) - 13 (Fri.), 2009  
10:00-18:00 \*Closed at 17:00 on the last day

**Venue:** Tokyo Big Sight / West Halls  
3-21-1 Ariake, Koto-ku, Tokyo 135-0063  
Japan  
Tel: +81-3-5530-1111  
<http://www.bigsight.jp/english/index.html>

**Floor Space:** 23,200m<sup>2</sup>

**Exhibitors:** 250 companies and organizations (tentative)  
(209 in 2008, 65 Foreign 144 Domestic)

**Visitors:** 35,000 (tentative) (31,396 in 2008)

**Admission Fee:** JPY 1,000 (tax included)

**Supported by (tentative):**

Ministry of Economy, Trade and Industry (METI), Japan External Trade Organization (JETRO), The Association of the Promotion of International Trade, Japan and Related Organizations & Embassies

**In Conjunction with (tentative):**

INTERIOR FESTIVAL 2009 : West Hall  
IPEC-2009(INTERIOR PRO EX CO) : West Hall  
JAPAN Home & building Show 2009 : East Hall

## Buyers find what they want at JAPANTEX.

**Window Treatments:** Curtains, Blinds, Screens, Curtain Rail, Upholstery, Fabrics, etc.

**Floor Coverings:** Carpets, Rugs, Wooden Flooring, Flooring Materials, Cork Tiles, Plastic Flooring, Tatami Mats, Textile, etc.

**Wall Coverings:** Wallpaper, Japanese Wall Paper, Paintings, Tiles, Fusuma Paper, Shoji Paper, etc.

**Home Fashion:** Bedroom & Bathroom Linens, Tableware, Design Parts, Interior Designed Electronics, Interior Gifts, etc.

**Workshops:** Sewing Machines, Glues, Repair Items, Equipment, Software, Printers, etc.

**Japanese-Traditional:** Fabrics, Japanese Paper, Wooden Products, Lacquer Products, etc.

**Furniture/Lighting/ Electrical products:** Furniture, Lightings, Built - in kitchen, Audio Visual System, Security

**Textile Designer:** Textile design, Textile pattern, etc.

**Interior Publishers:** Press, Media

## Visitors Specification in 2008. ( ):number of visitors

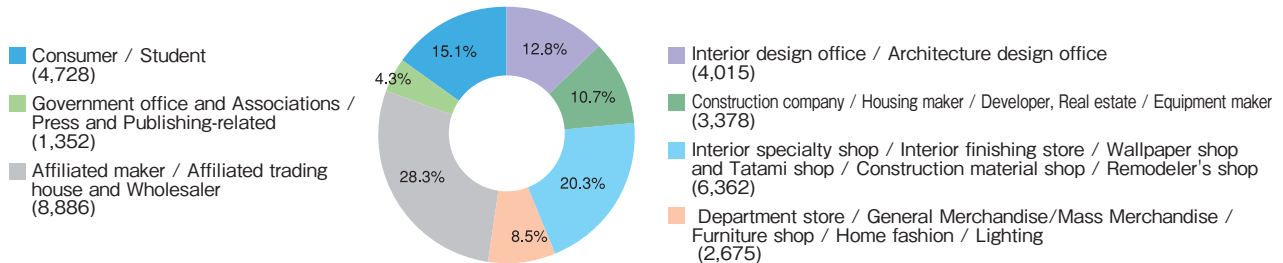

## A survey of Exhibitors in 2008

**Q1. What is your purpose of exhibiting products in the fair?**  
(Check all relevant items. / Number of answers: 265)

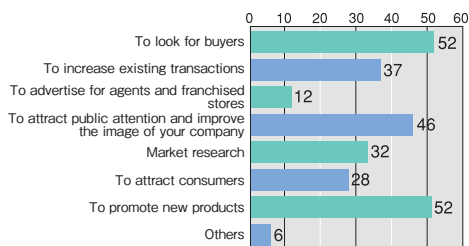

**Q3. What transactions do you expect to increase in the future?**  
(Check all relevant items. / Number of answers: 143)

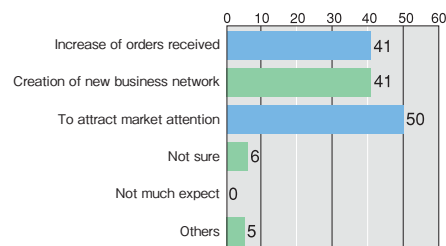

**Q2. How was the achievement of exhibiting?**

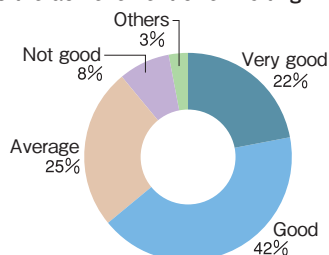

**Q4. Would you like to exhibit your products in JAPANTEX2009?**

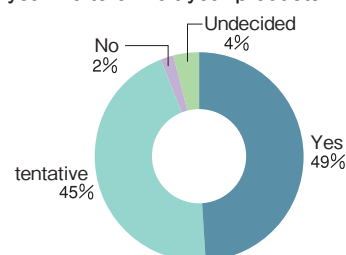

## Exhibit Fee

### Raw Space Only (6 booth units or more only)

1 booth (3m × 3m = 9m<sup>2</sup>)  
= **JPY 294,000** (tax included)  
(JPY 280,000)

- Fee includes : 9m<sup>2</sup> space and 300W main electrical power supply.
- \* Wall panels are NOT included.

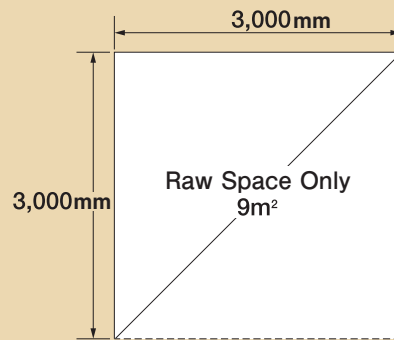

### Packaged Booth (1-5 booth units)



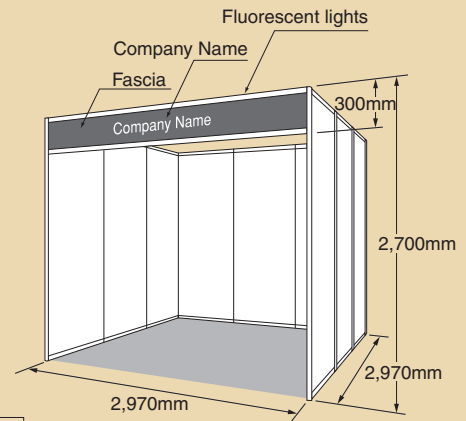

1 booth (3m × 3m = 9m<sup>2</sup>)  
= **JPY 399,000** (tax included)  
(JPY 380,000)

- Fee includes :
  - 9m<sup>2</sup> space
  - System wall panels
    - Fascia
    - Company name
    - Carpet (Gray)
  - Two fluorescent lights (40W)
  - 300W main electrical power supply



#### Corner Booth Fee (Extra charge)

A corner booth will be secured at extra charge.

Type of booth	Exhibit fee (tax included)	Corner Booth Fee	Total Amount (tax included)
1 booth 	JPY 399,000	+ JPY 31,500	<b>JPY 430,500</b>
2 booths 	JPY 798,000	+ JPY 31,500	<b>JPY 829,500</b>
3 booths 	JPY 1,197,000	No charge	<b>JPY 1,197,000</b>
4 booths 	JPY 1,596,000	No charge	<b>JPY 1,596,000</b>
4 booths 	JPY 1,596,000	+ JPY 63,000	<b>JPY 1,659,000</b>

## Application Procedure

- **Apply to:**  
Please complete the form and send application by FAX to:  
Nippon Interior Fabrics Association  
6F, Fukuda Bldg., 2-3-23, Hamamatsucho, Minato-ku,  
Tokyo 105-0013 Japan  
TEL: +81-3-3433-4521 FAX: +81-3-3433-7860
- **Application Deadline:**  
June 30 (Tue), 2009  
\* Application deadline may be shortened if all available exhibit space has been filled.
- **Payment Deadline:**  
July 31 (Fri), 2009  
Bank Account:  
Account name / Nippon Interior Fabrics Association  
Bank name / Mizuho Bank, Hamamatsucho Branch  
Account No. / 3120627  
\* Application will be confirmed upon completion of payment.
- **Cancellation charge:**  
On or before August 31 (Mon), 2009      50% of the exhibit fee  
After September 1 (Tue), 2009            100% of the exhibit fee
- **Booth Location:**  
Booth locations are decided by the organizer.
- **Copyright Protection:**  
If product designs or textile patterns are copied illegally, they can not be displayed. Please be sure to avoid this type of violation.
- **Cancellation of the Exhibition:**  
The organizer may postpone or cancel the Exhibition because of natural disasters such as earthquake, fire, etc. or any causes beyond its control. If the Exhibition is cancelled, the Exhibition Fee will be refunded to each exhibitor after deducting costs incurred. Other than such refund, no other compensation will be provided by the organizer.
- **Alteration or Cancellation of Application:**  
Any cancellation or alteration (reduction) in the size of exhibit space must be made in writing to the organizer. Cancellations or alterations made after the application has been accepted are subject to following fees (calculated as to date written notification received):

## Nippon Interior Fabrics Association

6F, Fukuda Bldg., 2-3-23, Hamamatsucho, Minato-ku, Tokyo 105-0013 Japan

TEL+81-3-3433-4521、FAX+81-3-3433-7860

URL: <http://www.japantex.jp/english/index.html>

Please visit our website for the latest information!

# JAPANTEX2008 Exhibitors List

※Alphabetical order

## 209 companies/organizations

(Japanese:144 Overseas:65 from 15 countries and regions Austria, Belgium, China, Egypt, Germany, Holland, India, Iran, Italy, Korea, Lithuania, Russia, Spain, Taiwan, Turkey)

- **A** Alexander's Collection (MARIESRAG Co.,Ltd.)  
ALHAMBRA INTERNACIONAL  
ALL JAPAN BEDDING GOODS ASSOCIATION  
ALULU Corporation (Fujiyoshida Woven Cloth Cooperative Society)  
Amaike Textile Industry Co.,Ltd. (Otsuma Women's University)  
ANY TEKSTIL SAN. TIC. VE PAZ. A. S.  
AOYA WASHI CO.,LTD.  
AOYATEX CO.,LTD.  
ART CLAY CO.,LTD. (LAPOGE CO.,LTD.)  
ASAHI ORIMONO (Gifushi Habitat Textile Association)  
ASWAN CORPORATION  
Awagami Factory
- **B** BAUMANN DEKOR AUSTRIA  
Beaulieu International Group (Yarn & Fibre BU) Ideal Fibres & Fabrics Wielsbeke n.v.  
BEIJING COSHEEN HOME TEXTILE CO.,LTD.  
BINGOYA CO.,LTD.  
BRITISH WOOL MARKETING BOARD (JAPAN CARPET MANUFACTURES ASSOCIATION)
- **C** CARPET GALLERY CO.,LTD.  
CHANGSHU JINXIU GOLDTEX CO.,LTD.  
CHANGSHU PAITE ORNAMENTATIONS CO.,LTD.  
CHANGSHU WESLEY TEXTILE CO.,LTD.  
CHINA NATIONAL ARTS & CRAFTS IMP. & EXP. CORP  
CHINA PEACE CORPORATION  
CHORI Co.,LTD.  
COCO-MAT (CHINA) LTD.  
Coulisse (MANAS TRADING INC.)
- **D** DAECHUNG TEXTILE CO.  
DAHKAN CO.,LTD.  
DAISEN Ltd.  
DANDONG JINLI DRAWNWORK CO.,LTD.  
DIA CARPET CO.,LTD. (JAPAN CARPET MANUFACTURES ASSOCIATION)
- **E** ENIAC INTERNATIONAL Inc.
- **F** FINICOP (MARIESRAG Co.,Ltd.)  
FUJILIGHT CARPET CO.,LTD.  
Fujiyoshida Woven Cloth Cooperative Society  
FULL COLOR CO.,LTD.  
Funakubo Textile Ltd. (Fujiyoshida Woven Cloth Cooperative Society)
- **G** G M FABRICS  
GEE MEI HANDICRAFT COMPANY  
GEMITEX (MARIESRAG Co.,Ltd.)  
Gifushi Habitat Textile Association  
GISO (Gifushi Habitat Textile Association)  
GOYO SHOJI (Gifushi Habitat Textile Association)
- **H** HACHETTE FUJINGAHO  
HAINING LIDUO CARPET CO.,LTD.  
HANGZHOU CHENGJIA GARMENT CO.,LTD.  
HANGZHOU CRAFTS & TEXTILE CO.,LTD.  
HANGZHOU TONGLI TEXTILE CO.,LTD.  
HASETORA SPINNING CO.,LTD. (JAPAN CARPET MANUFACTURES ASSOCIATION)  
HEBEI SHUANGJIAN TEXTILE AND MACHINE CO.,LTD.  
HIGH-REFINEMENT (NANTONG) CURTAIN ARTICLES CO.,LTD.  
Hikari-Textile Ltd. (Fujiyoshida Woven Cloth Cooperative Society)  
HIRAKU SPINNING CO.,Ltd. (JAPAN CARPET MANUFACTURES ASSOCIATION)  
HORISHO (Gifushi Habitat Textile Association)
- HOTTA CARPET CO.,LTD. (JAPAN CARPET MANUFACTURES ASSOCIATION)  
HOZUMI SEN-I KOGYO CO.,LTD. (Suzuharu Co.,Ltd.)  
HUAIAN KANWAY CHEMICAL TECHNOLOGY CO.,LTD.  
Huis Corporation
- **I** IGREK L.P.Co.  
IKEHIKO CORPORATION (OKI TOWN SOCIETY OF COMMERCE AND INDUSTRY)  
ING GRAPHIC ARTS  
INOUE SUDARE CO.,LTD.  
INSTITUTE OF INSPECTION CLEANING & RESTORATION CERTIFICATION  
JAPAN CLUB (JAPAN CARPET MANUFACTURES ASSOCIATION)  
INTERIOR JOUHO KIKAKU LTD.  
Interior Sangyo Center Co.,Ltd. (INTERIOR TIMES CO.,LTD.)  
INTERIOR TIMES CO.,LTD.  
INTERNATIONAL DESIGNERS ASSOCIATION  
INVISTA (Japan) K.K.  
IWASE PRINCE CO.,LTD. (LAPOGE CO.,LTD.)
- **J** JAPAN CARPET CO.,LTD. (JAPAN CARPET MANUFACTURES ASSOCIATION)  
JAPAN CARPET MANUFACTURES ASSOCIATION  
JAPAN CONSTRUCTION INTERIOR COOPERATIVES FEDERATION  
JAPAN FIRE RETARDANT ASSOCIATION  
JAPAN INTERIOR DECORATION ASSOCIATION  
JAPAN RUG ENTHUSIASTS CLUB  
Japanesque Modern Committee  
JBS CORPORATION  
JIANDE XINHAIJIN HOMETEXTILES CO.,LTD.  
JIANGSU HENGDA PLUSH CO.,LTD.  
JIANGSU KAILI CARPET CO.,LTD.  
JIANGSU TONGYE INDUSTRY CO.,LTD.  
JIAXING HAUYI TEXTILE CO.,LTD.  
JINGJIANG HAPPY TEXTILE CO.,LTD.
- **K** KASHIWAGI (Fujiyoshida Woven Cloth Cooperative Society)  
KAWAJIN CO.,LTD.  
Kawashima Selkon Textiles Co.,LTD.  
Kawashima Selkon Textiles Co.,Ltd. (JAPAN CARPET MANUFACTURES ASSOCIATION)  
KAZUMA CO.,LTD.  
KOEI SANGYO CO.,LTD.  
KUWA DESIGN STUDIO  
KYOKKO CO.,LTD.  
KYOKUTO SANKI CO.,LTD.
- **L** LAPOGE CO.,LTD.  
LeaLea Enterprise Co.,Ltd. (Li Peng Enterprise Co.,Ltd.)  
LEI TSU  
Li Peng Enterprise Co.,Ltd.  
LIBOLON (Li Peng Enterprise Co.,Ltd.)  
LIC CO.,LTD.  
Lilycolor Co.,Ltd.  
Link Earth  
LIYANG XINYUAN CURTAIN PRODUCTS CO.,LTD.
- **M** MANAS TRADING INC.  
MARIESRAG Co., Ltd.  
MARUSA (Gifushi Habitat Textile Association)  
MARUSEI CO.,LTD.  
MARUSU SUZUKI (Gifushi Habitat Textile Association)  
MARUTAKA KOGYO CO.,LTD.  
MITSUFUKU CO.,LTD.  
Miyashita Orimono Co.,Ltd. (Fujiyoshida Woven Cloth Cooperative Society)

- MORISHIMASOUGEI (Gifushi Habitat Textile Association)  
MORITO CO.,LTD.  
MURAKAMI CARPET CO.,LTD. (JAPAN CARPET MANUFACTURES ASSOCIATION)
- **N** Nabeshima Dantsu Yoshijimake Ltd.  
NAKANIHON JUKI CO.,LTD.  
Namx Co.,Ltd.  
NANTONG GANFER HOME TEXTILES CO.,LTD.  
NICHIBEI CO.,LTD.  
NIF DATABASE  
NIHON SEN-I SHIMBUN CO.,LTD.  
NIHON SHINSO SHIMBUN CO.,LTD.  
NIHON SHORYOKU CO.,LTD. (JAPAN CARPET MANUFACTURES ASSOCIATION)  
NILE TEXTILE INDUSTRIES S.A.E.  
NINGBO JUZHENG SILK I/E CO., LTD.  
NISHIBU CO.,LTD.  
NISSEKI PLASTO CO.,LTD.//Milife Office Marketing Group  
NISSHIKI CO.,INC. (JAPAN CARPET MANUFACTURES ASSOCIATION)  
NISSIN CO.,LTD. (JAPAN CARPET MANUFACTURES ASSOCIATION)
- **O** OHNO INC. (JAPAN CARPET MANUFACTURES ASSOCIATION)  
OHTAORIMONO (Gifushi Habitat Textile Association)  
OKI TOWN SOCIETY OF COMMERCE AND INDUSTRY  
ONAO CO.,LTD.  
Otsuma Women's University, Faculty of Home Economics,  
Textile Science,Fashion Creation and Surface science laboratory  
Oyamada Co.,Ltd. (Fujiyoshida Woven Cloth Cooperative Society)
- **P** PAUL SALON  
Persian World Co.,Ltd.  
PS COMPANY LTD.  
PUJIANG COUNTY HUAFENG TEXTILE PRODUCTS FACTORY
- **R** RUNON CO.,LTD.
- **S** SANGETSU Co.,Ltd.  
Sanko Shoji Co.,Ltd.  
SANKYO (Gifushi Habitat Textile Association)  
Saraswati Global Ltd.  
SCM Promotion Corporative Association (NIF DATABASE)  
Seiko Epson Corporation (Otsuma Women's University)  
SELF HOMETEXTILES (NANTONG) CO.,LTD.  
SENKEN SHINBUN CO.,LTD.  
SHANDONG KASENTEX CO.,LTD.  
SHANGHAI CATHAYA INTERNATIONAL TRADING CO.,LTD.  
Shanghai Revon Co.Ltd.  
SHANGHAI TEXTFIBRE LTD.  
SHANGHAI WEILE TEXTILES CO.,LTD.  
SHAOXING JIALONG KNITTING & TEXTILE CO.,LTD.  
SHINKO CO.,LTD.  
Silent Gliss Corporation  
SINCOL INTERIOR CO.,LTD.  
SIULAS  
SOEJIMA ISAO SHOTEN CO.LTD. (OKI TOWN SOCIETY OF COMMERCE AND INDUSTRY)  
SOKEN Co.,Ltd. (MARUTAKA KOGYO CO.,LTD.)  
SUMINOE TEXTILE CO.,LTD.  
SUMINOE TEXTILE CO.,LTD. (JAPAN CARPET MANUFACTURES ASSOCIATION)  
SUMIYOSHI CO.,LTD. (JAPAN CARPET MANUFACTURES ASSOCIATION)  
SUNCHEMILCAL CO.,LTD. (JAPAN CARPET MANUFACTURES ASSOCIATION)  
SUN EIGHT CO.LTD. (OKI TOWN SOCIETY OF COMMERCE AND INDUSTRY)  
SUNGAREN (NISHIO RENT ALL CO.,LTD.)  
SUNROSE CO.,LTD.  
Suzuharu Co.,Ltd.  
SZIPT LTD.,JIANGSU METALS & MINERALS IMPORT & EXPORT (GROUP)
- **T** T.I.C Co.,LTD.  
TACHIKAWA CORPORATION  
Taisei Corporation  
TAJIMA,INC. (JAPAN CARPET MANUFACTURES ASSOCIATION)  
Tanabe Textile,Ltd. (Fujiyoshida Woven Cloth Cooperative Society)  
TECIDO & CO.,LTD.  
Teijin Fiber Ltd. (Otsuma Women's University)  
THE TEXTILE DESIGN ASSOCIATION OF JAPAN  
THE JAPAN WOOL TEXTILE CO.,LTD. (JAPAN CARPET MANUFACTURES ASSOCIATION)  
THE WOOLMARK COMPANY (JAPAN CARPET MANUFACTURES ASSOCIATION)  
TIANJIN JINGFENGSHENG HOUSE PRODUCTS CO.,LTD.  
TOA CORK CO.,LTD.  
TOABO MATERIAL CO.,LTD. (JAPAN CARPET MANUFACTURES ASSOCIATION)  
TOKAI VISION Marketing Co.,Ltd.  
TOKIWA INDUSTRIES LTD.  
TOKUYAMA Corporation (TOKIWA INDUSTRIES LTD.)  
TOLI Corporation  
TOLI Corporation (JAPAN CARPET MANUFACTURES ASSOCIATION)  
TOSHIN (OKI TOWN SOCIETY OF COMMERCE AND INDUSTRY) CO.,LTD.  
TOSO COMPANY,LIMITED  
TOSOKYO · JCIFKANTO · TOKYOGINOUSIKAI  
TOWA ORIMONO CO.,LTD. (JAPAN CARPET MANUFACTURES ASSOCIATION)  
Trevira GmbH (Trevira Japan Representative)
- **U** UNIVERSAL TRESURE CO.,LTD.
- **W** Wallcoverings Association of Japan  
WENZHOU ZHULIAN INDUSTRIAL CO.,LTD.  
WILDWOOD JAPAN LTD.  
Window Treatment Industry Activation Project  
WOOLS OF NEW ZEALAND (JAPAN CARPET MANUFACTURES ASSOCIATION)
- **Y** Yamagata Carpet Industry Cooperative  
YAMAMOTO INDUSTRIAL CO.,LTD. (JAPAN CARPET MANUFACTURES ASSOCIATION)  
YANCHENG SENDE TEXTILES CO.,LTD.  
YANTAI TOPART EMBROIDERY CO.,LTD.  
YASUDASHOTEN & Co.  
YAYOI CHEMICAL INDUSTRY CO.,LTD.  
YOKOTA Co.,Ltd.  
YONEZAWA BUSSAN CO.,LTD.  
YOSHIDAFUSA ORIMONO CO.,LTD. (JAPAN CARPET MANUFACTURES ASSOCIATION)
- **Z** ZHEJIANG HUAXING FEATHER & DOWN PRODUCTS CO.,LTD.  
ZHEJIANG TONGXIANG FOREIGN TRADE GROUP CO.,LTD.  
ZHEJIANG YITONG ARTS & CRAFTS CO.,LTD.  
ZOLLANVARI (CARPET GALLERY CO.,LTD.)

**FAX:+81-3-3433-7860**

Deadline of application : June 30 (Tue), 2009

**The 28th**  
**JAPANTEX2009**  
INTERIOR TREND SHOW

**Application Form**

To:

Nippon Interior Fabrics Association

6F. Fukuda Bldg., 2-3-23, Hamamatsucho, Minato-ku, Tokyo 105-0013 Japan

TEL: +81-3-3433-4521 FAX: +81-3-3433-7860

**Please fill in the below and send it by FAX.**

We are applying for The 28th JAPANTEX2009 INTERIOR TREND SHOW as follows:

Head Office

Company Name			
Address	URL:		
TEL		FAX	

Contact Person

Company Name			
Name		Dept.	
Address	URL:		
TEL		FAX	
Email			

Exhibitor Classification

Company       Organization       Press / Media       Designer / Studio

Raw Space Only (6 booth units or more only)    JPY 294,000 (tax included) ×    booth = \_\_\_\_\_

Packaged Booth (Please Check in the Box)

- |  |                              |   |                           |
|--|------------------------------|---|---------------------------|
| <input type="checkbox"/> 1. One Booth              | JPY 399,000 (tax included)   | <input type="checkbox"/> Corner Booth Guarantee fee | JPY 31,500 (tax included) |
| <input type="checkbox"/> 2. Two Booth              | JPY 798,000 (tax included)   | <input type="checkbox"/> Corner Booth Guarantee fee | JPY 31,500 (tax included) |
| <input type="checkbox"/> 3. Three Booth            | JPY 1,197,000 (tax included) | <input type="checkbox"/> Corner Booth Guarantee fee | No Need                   |
| <input type="checkbox"/> 4. Four Booth<br>(Wide)   | JPY 1,596,000 (tax included) | <input type="checkbox"/> Corner Booth Guarantee fee | No Need                   |
| <input type="checkbox"/> 5. Four Booth<br>(square) | JPY 1,596,000 (tax included) | <input type="checkbox"/> Corner Booth Guarantee fee | JPY 63,000 (tax included) |

Exhibiting Item / Explanation of Items to be displayed

\*The information contained on this application form will be retained by Nippon Interior Fabrics Association for various announcements, etc. regarding future editions of JAPANTEX. Please contact Nippon Interior Fabrics Association if use of this information is objectionable.

Date

Signature

# JAPANTEX2009 General Exhibition Rules

## 1 Application to Exhibit

Those who wish to join the Exhibition are asked to submit to Nippon Interior Fabrics Association by fax, the application form in accordance with the application procedure described in the said form after agreeing to observe these exhibition rules.

## 2 Payment of Exhibition Fee

Exhibitors shall pay their full Exhibition Fee by the date specified in the Exhibition Fee Invoice. If the payment is not confirmed by the organizer by the specified date, the organizer has the right to cancel the exhibitor's application.

## 3 Alteration and Cancellation of Application

Any cancellation or alteration (reduction) in the size of exhibit space must be submitted in writing expressing the reason. Cancellations or alterations made after the application has been accepted are subject to the following fees (calculated as to date written notification received) :

Until Aug 31 (Mon), 2009	50% of the exhibition fee
From Sep 1 (Tue), 2009	100% of the exhibition fee

Any exhibitor who fails to pay the amount equal to that set forth in paragraph above of this article at the time of alteration or cancellation shall pay said amount immediately.

If the sum paid at the time of alteration or cancellation exceeds the relevant amount set forth above, the organizer shall refund the excess amount to the exhibitor.

## 4 Prohibition of Booth Subleasing

Exhibitors are prohibited to sublease, sell, exchange, or assign their booth without the organizer's specific approval.

## 5 Booth Allocation

Booth allocation shall be determined by the organizer. Exhibitors cannot object to the allocation once it is determined. The organizer reserves the right to change the booth allocation after announcement. If any exhibitor wishes to cancel its exhibit due to dissatisfaction with the booth allocation, the normal procedure for cancellation in payment of the prescribed cancellation fee will be required. The exhibitor cannot claim for compensation due to change of booth allocation.

## 6 Use of Booth

- (1) All publicity and sales activities by exhibitors must be performed within their own booth. Activities using the areas outside the booth shall be prohibited. In conducting publicity activities, exhibitors will be responsible for not causing congestion of the aisles around their booth.
- (2) Where booths are adjacent to each other, exhibitors shall agree not to arrange their booth displays or decorations in such manner as to interfere with the adjacent booths. Should any exhibitor of the adjacent booth make a claim, the organizer will determine whether it is necessary to change the booth arrangement in view of management of the exhibition. If the organizer determines it to be necessary, the exhibitor must comply with the decision and change the booth arrangement.
- (3) The organizer reserves the right to restrict displays that are considered to have problems due to their sound, operational methods, materials, or any other reasons and to ban or remove exhibits not suitable for the purpose of the exhibition from the viewpoint of the organizer.

## 7 Management of Exhibits and Indemnity

Individual exhibitors shall take full responsibility for the management and security/safety of exhibits and activities held within their booth, and the organizer shall be indemnified and held harmless from and against any losses or damages arising out of any causes whatsoever.

## 8 Application Termination

The organizer may terminate the exhibition application in case the exhibitor falls under any of the following cases:

- the Exhibition Fee has not been paid by the specified date;
- the Exhibitor violates the provisions of articles 6 concerning the use of booth, etc. and does not obey the instructions issued by the organizer regarding correction thereof;
- any other cases in which serious trouble is deemed likely to affect the normal and smooth management of the exhibition.

## 9 Compensation for Damages

Exhibitors shall compensate damages to the facilities of the site or the building of the exhibition, or bodily injuries due to or arising from negligence of fault on their own part or by their agents.

## 10 Cancellation of the Exhibition

The organizer may postpone or cancel the Exhibition because of natural disasters such as earthquake, fire, etc. or any causes beyond its control. If the Exhibition is cancelled, the Exhibition Fee will be refunded to each exhibitor after deducting costs incurred. Other than such refund, no other compensation will be provided by the organizer.

## 11 Observance of the Rules

Exhibitors shall deem a series of regulations set forth by the organizer as part of these Exhibition Rules, and agree to observe them. Moreover, exhibitors shall understand that all said rules and regulations are intended to protect the benefit and well-being of the exhibition and agree to abide by them.

## 12 Copyright Protection

If product designs or textile patterns are copied illegally, they can not be displayed.

## 13 Governing Law

The Exhibition contract shall be governed by, and construed and interpreted in accordance with the laws of Japan.

## 14 Jurisdiction

In case any disputes arise out of or in connection with the exhibit contract, the Tokyo District Court in Japan shall have the sole and exclusive jurisdiction.